

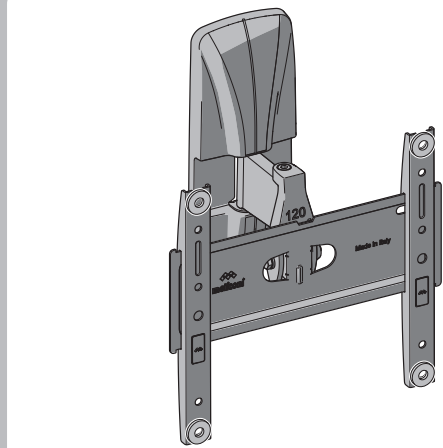

SLIMSTYLE PLUS 200 ST



- IT ISTRUZIONI DI MONTAGGIO
- FR INSTRUCTIONS DE MONTAGE
- EN MOUNTING INSTRUCTIONS
- DE MONTAGEANLEITUNG
- NL MONTAGEVOORSCHRIFT
- ES GUÍA DE MONTAJE
- PT INSTRUÇÕES DE MONTAGEM
- PL INSTRUKCJA MONTAŻU
- CZ NÁVOD K MONTÁŽI
- RO INSTRUCȚIUNI DE MONTARE
- HU SZERELÉSI ÚTMUTATÓ
- FI ASENNUSOHJEET
- SK NÁVOD NA MONTÁŽ
- SL NAVODILA ZA MONTAŽO
- MK INSTRUKCIJE ZA MONTAŽU
- SQ UDHËZIME PËR MONTIMIN



Qualità certificata
Certified quality

Meliconi S.p.A. - V. Minghetti, 10
40057 Cadrano di Granarolo E. (BO) Italy
www.meliconi.com e-mail: info@meliconi.com



Pensez à donner ou recycler.
OU ASSOCIATION MARGAIN OU DÉCHÈTERIE
<https://quefairedemesdechets.fr>

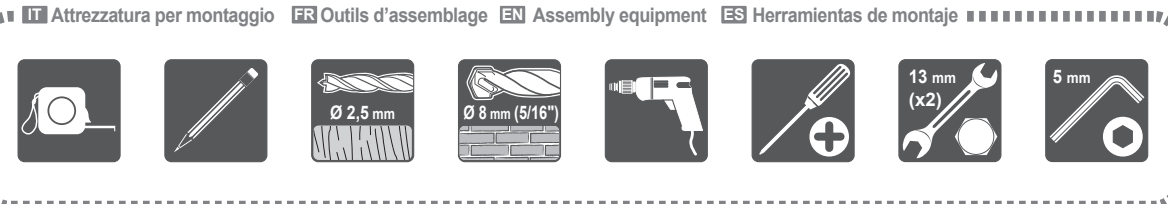

IT Attrezzatura per montaggio FR Outils d'assemblage EN Assembly equipment ES Herramientas de montaje

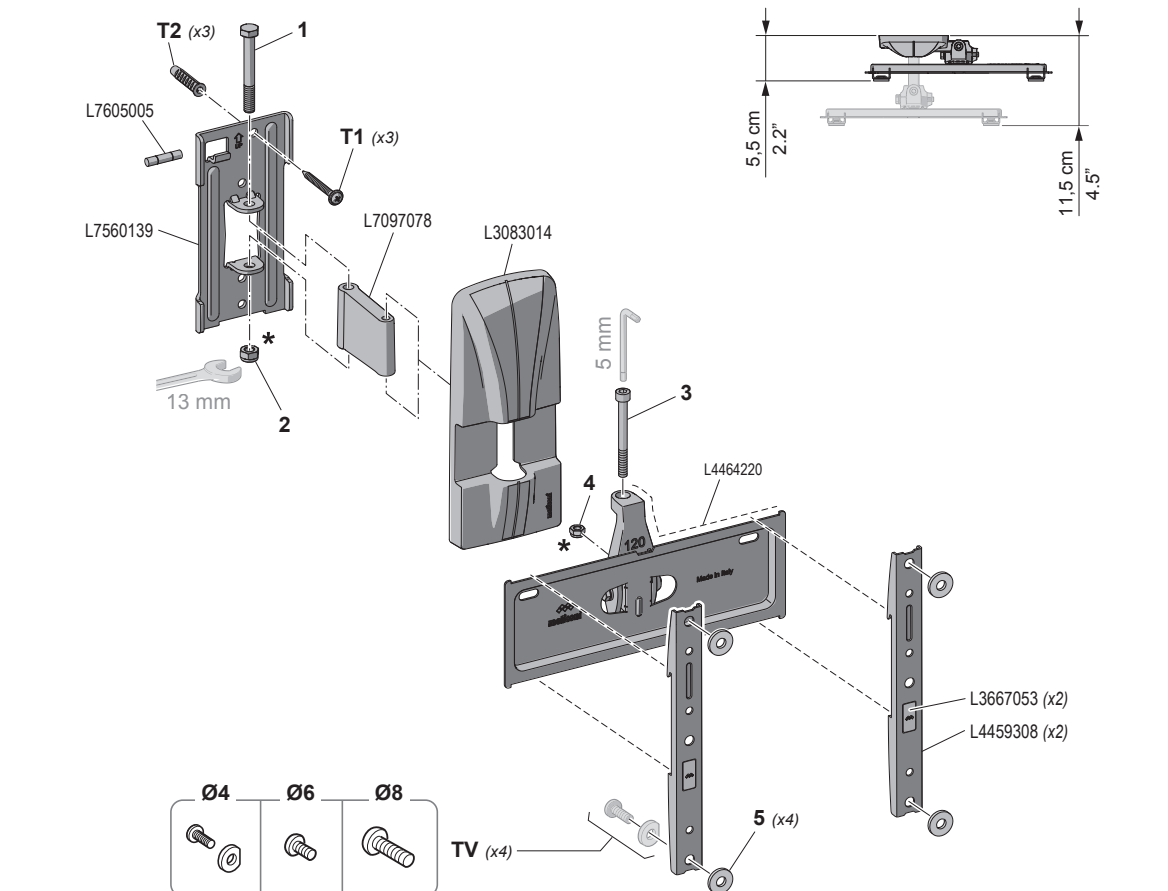

* IT Dado autobloccante, specifico per evitare svitamenti accidentali. Avvitare in maniera decisa, con gli appositi attrezzi, anche dopo aver avvertito la prima resistenza.
FR Écrou autobloquant, conçu pour éviter tout desserrage accidentel. Serrer fermement, avec les outils appropriés, même après avoir perçu la première résistance.
EN Self-locking nut, designed to prevent accidental loosening. Tighten firmly, with the correct tools, even after feeling the first resistance.
ES Tuerca autobloqueante para evitar que se afloje. Enroscar a fondo con las herramientas específicas, incluso después de haber notado la resistencia inicial.

