

600SDRP Plus

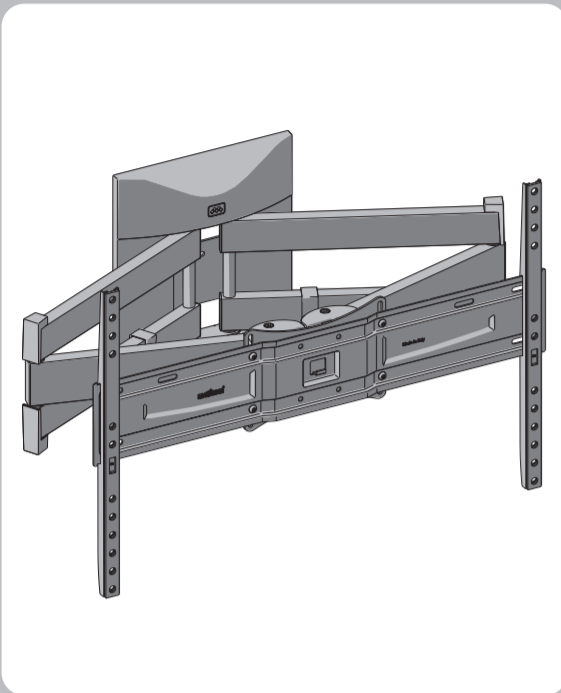

IT ISTRUZIONI DI MONTAGGIO  
FR INSTRUCTIONS DE MONTAGE  
EN MOUNTING INSTRUCTIONS  
DE MONTAGEANLEITUNG  
NL MONTAGEVOORSCHRIFT  
ES GUÍA DE MONTAJE  
PT INSTRUÇÕES DE MONTAGEM  
PL INSTRUKCJA MONTAŻU  
CZ NÁVOD K MONTÁŽI  
RO INSTRUCȚIUNI DE MONTARE  
HU SZERELÉSI ÚTMUTATÓ  
FI ASENNUSOHJEET  
SK NÁVOD NA MONTÁŽ  
SL NAVODILA ZA MONTAŽO  
MK INSTRUKCIJI ZA MONTAŽA  
SQ UDHËZIME PËR MONTIMIN



Qualità certificata  
Certified quality

Meliconi S.p.A. - V. Minghetti, 10  
40057 Cadrano di Granarolo E. (BO) Italy  
www.meliconi.com e-mail: info@meliconi.com



Pensez à donner ou recycler.  
ASSOCIATION MAGASIN DÉCHÈTÈRE  
https://quefairemesdechets.fr

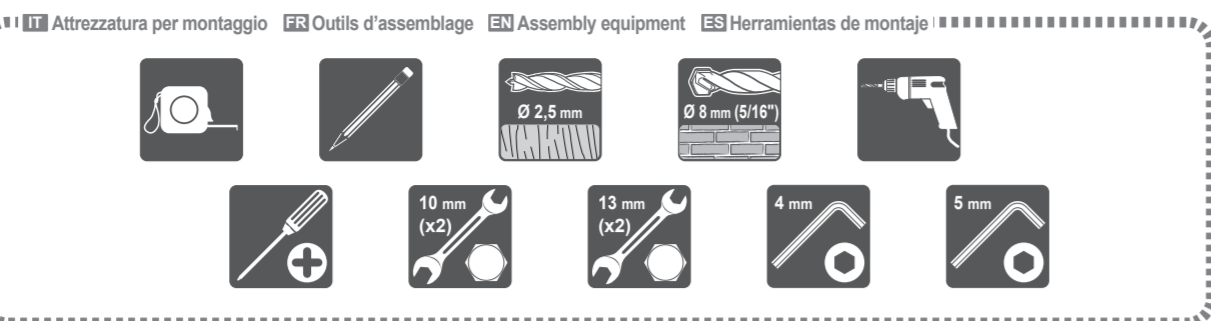

IT Dati tecnici FR Caractéristiques techniques EN Technical data ES Datos técnicos

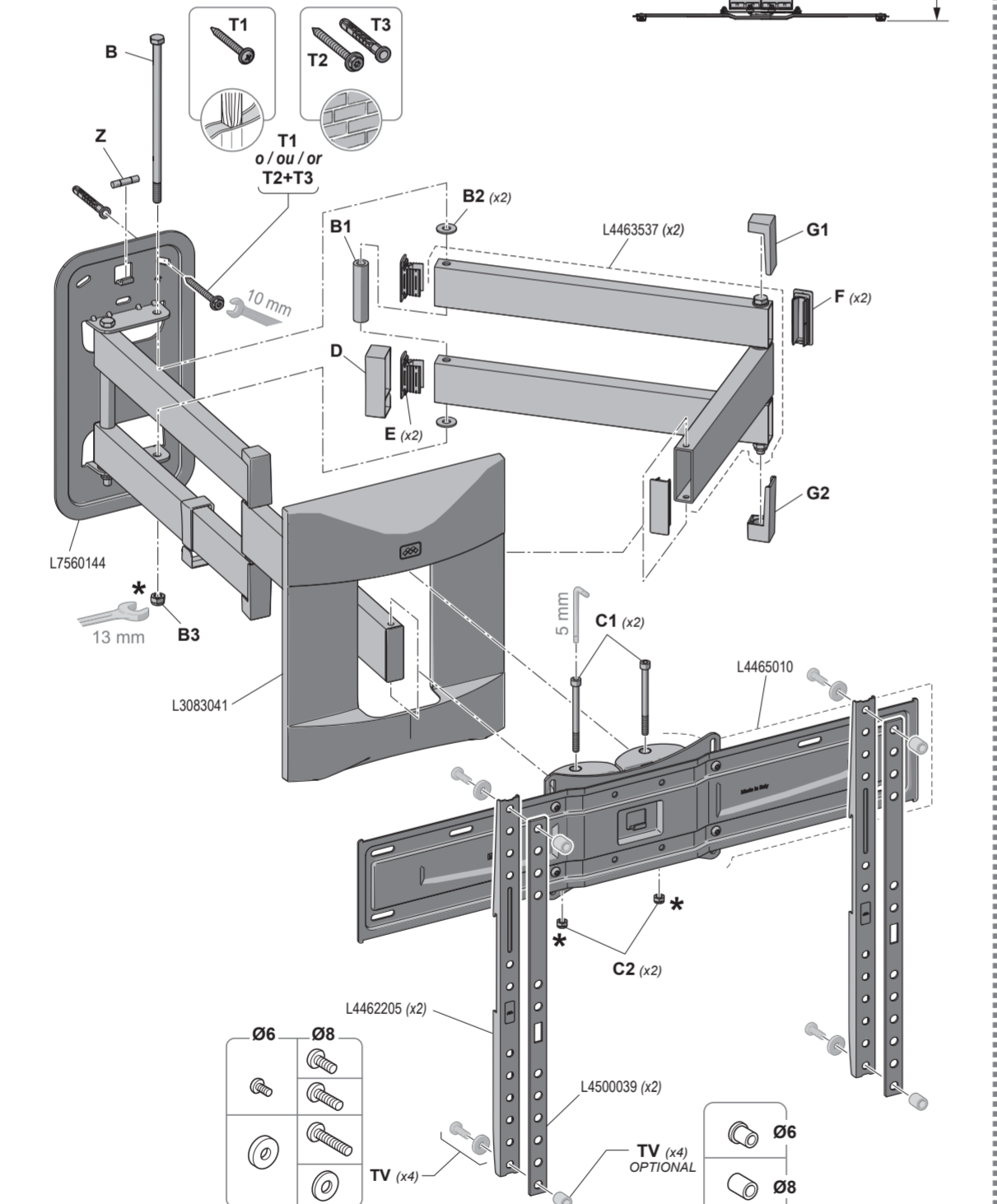
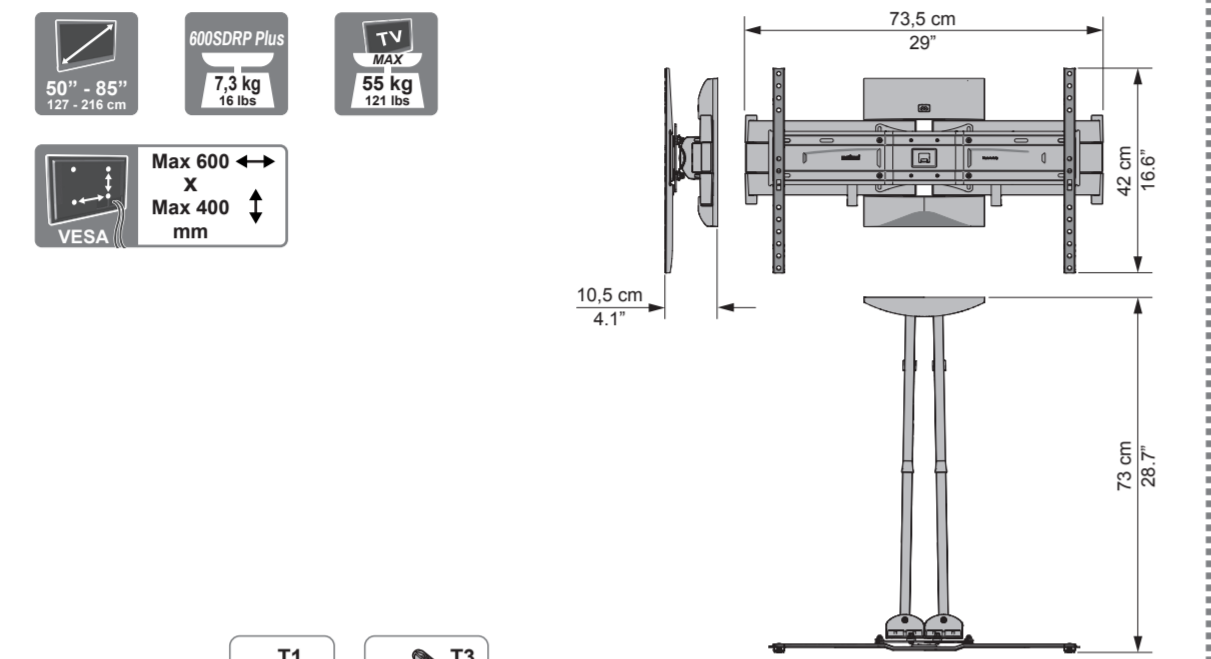

IT Dado autobloccante, specifico per evitare svitamenti accidentali. Avvitare in maniera decisa, con gli appositi attrezzi, anche dopo aver avvertito la prima resistenza.  
FR Écrou autobloquant, conçu pour éviter tout desserrage accidentel. Serrer fermement, avec les outils appropriés, même après avoir perçu la première résistance.  
EN Self-locking nut, designed to prevent accidental loosening. Tighten firmly, with the correct tools, even after feeling the first resistance.  
ES Tuerca autobloqueante para evitar que se afloje. Enrosca a fondo con las herramientas específicas, incluso después de haber notado la resistencia inicial.

